

100-metre wire-cable tethers attached to 25-metre chain terminating at midstream screw moorings, upstream and downstream

Tide flow

Tether attaches ~33% back from bow through base of centreboard, for manoeuvrability and to keep cable below propellers and other appendages of passing craft.

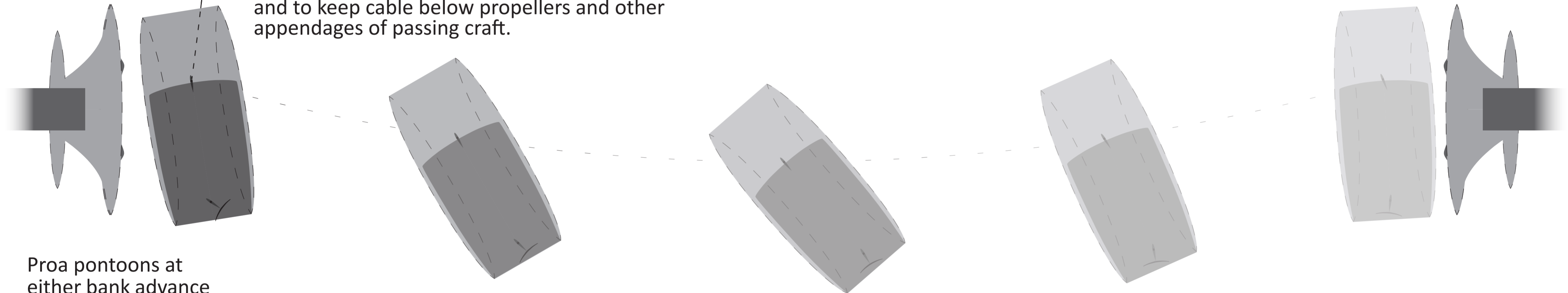

Proa pontoons at either bank advance and retreat with tide to minimise visual impact and constriction of navigable waterway

Ferry reacting to tide flow

~75-metre near-full tide width

Operation of electric-auxillary reaction ferry at Pūhoi river-mouth – near-full tide manoeuvre